

TM30A-D



### Typical Applications

- Industrial pressure and vacuum applications
- Portable analytical instruments
- Medical diagnostic equipment
- Ozone equipment
- Air quality sampling monitors
- Respiration monitors
- Lab equipment
- Gas or odor leak detectors
- Ink-jet printer

### Features

- Highest performance/size ratio
- Low noise and vibration
- Long service life
- Compact and robust design
- Uncontaminated transfer
- High level of gas tightness
- Extreme chemical resistance
- Customizing available
- Can be mounted in any plane

### Structure

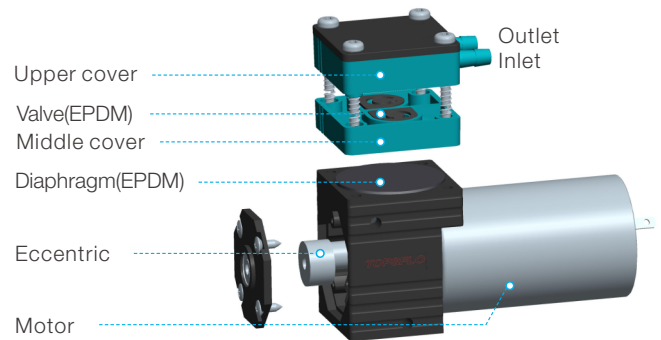

### Specification

Model	Pressure Pump (Item Number)	Vacuum Pump (Item Number)	Rated Voltage (VDC)	No-load Current (A)	Max Pressure (Kpa)	Max Vacuum (Kpa)	Max Flow (L/min)	Motor Type	Lifetime (Hours)
TM30A-D	TM30A-D12-P12004	TM30A-D12-V7004	12	0.24	120	-70	4	BLDC	15,000
	TM30A-D24-P12004	TM30A-D24-V7004	24	0.15	120	-70	4	BLDC	15,000

### Curve

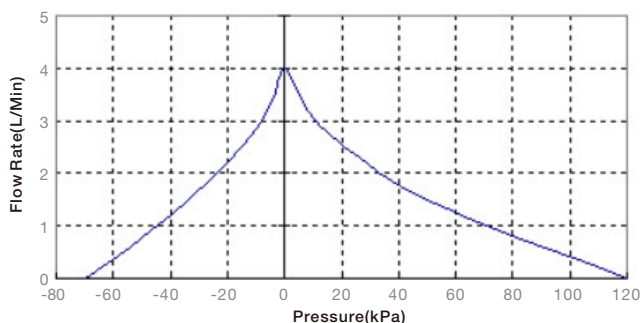

### Dimension (mm)

