

TM30A-B

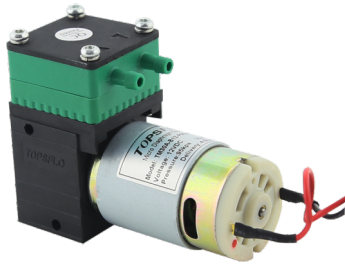

### Typical Applications

- Industrial pressure and vacuum applications
- Portable analytical instruments
- Medical diagnostic equipment
- Ozone equipment
- Air quality sampling monitors
- Gas or odor leak detectors
- Ink-jet printer

### Features

- Highest performance/size ratio
- Low noise and vibration
- Lasts reliably longer
- Compact and robust design
- Uncontaminated transfer
- High level of gas tightness
- Extreme chemical resistance
- Customizing available
- Can be mounted in any plane

### Structure

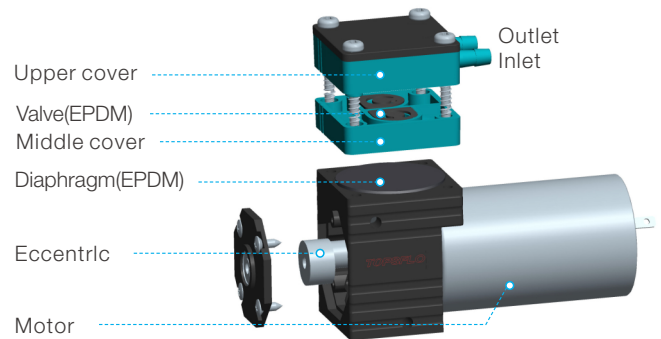

### Specification

Model	Pressure Pump (Item Number)	Vacuum Pump (Item Number)	Rated Voltage (VDC)	No-load Current (A)	Max Pressure (Kpa)	Max Vacuum (Kpa)	Max Flow (L/min)	Motor Type	Lifetime (Hours)
TM30A-B	TM30A-B12-P9504	TM30A-B12-V6004	12	0.4	95	-60	4	Brush Motor	1,000
	TM30A-B24-P9504	TM30A-B24-V6004	24	0.2	95	-60	4	Brush Motor	1,000

**Application Conditions:**

• Medium temperature: 5°C~60°C

• Ambient temperature: -20°C~60°C

### Curve

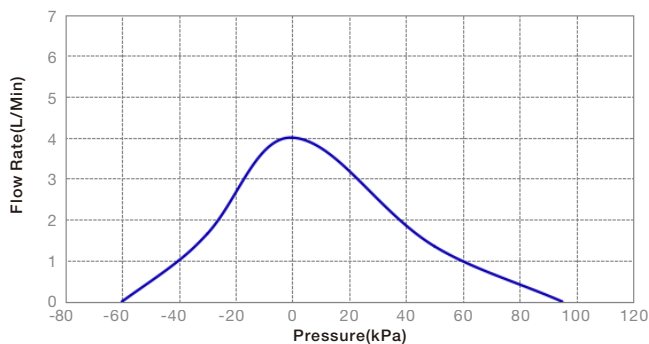

### Dimension (mm)

