

TF51-A

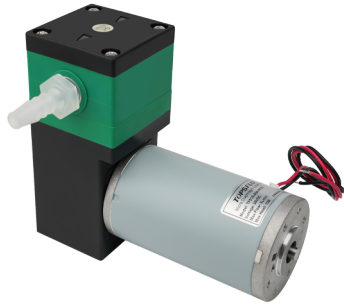

Typical Applications

- Industrial vacuum applications
- Portable Analytical Instruments
- Medical Diagnostic Equipment
- Environmental/water treatment
- Food industry
- Laboratory
- Cleaning industry
- Printing
- Fireplace

Features

- Small and powerful
- Self-priming and excellent for pressure
- Dry running, durable and maintenance free
- Lasts Reliably Longer
- Uncontaminated flow
- Little vibration
- High level of gas tightness
- Extreme chemical resistance
- Optimal solution for your application

Structure

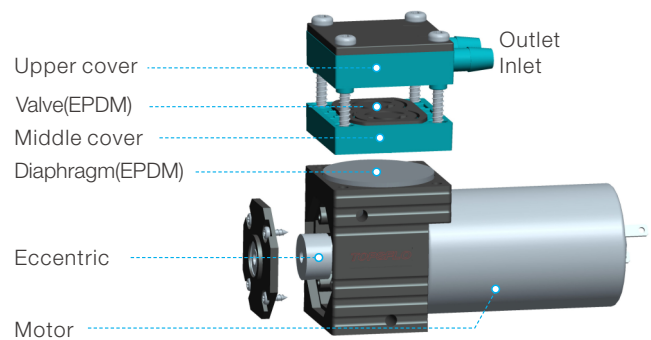

Specification

Model	Liquid Pump (Item Number)	Rated Voltage (VDC)	No Load Current (A)	0 D [+ H D (M)	GMax Vacuum (KPa)	Max Flow (L/min)	Motor Type	Lifetime (Hours)
TF51A-A	TF51A-A6-W103	6	2	10	-40	3	Brush Motor	3,000
	TF51A-A12-W103	12	1	10	-40	3	Brush Motor	3,000
	TF51A-A24-W103	24	0.65	10	-40	3	Brush Motor	3,000

Application Conditions:

• Medium temperature: 5°C~60°C

• Ambient temperature: 5°C~70°C

Curve

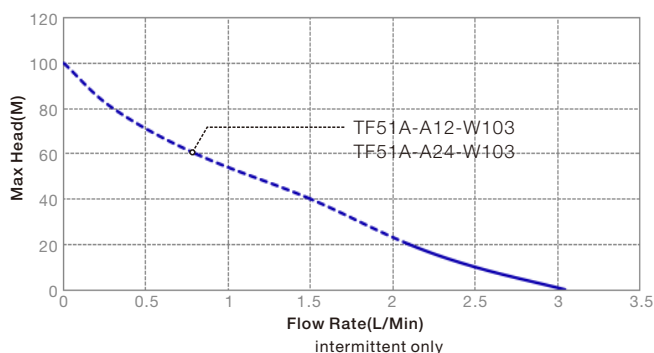

Dimension (mm)

